

**GAO-A2, GMH-A2, and GML-A2  
Gas Pressure Switch  
Installation Instructions**

**SPECIFICATIONS**

High/low ventless gas pressure switch (SPDT) with automatic or manual reset. Includes visual indication of switch position. Mounts directly to various ports on the SV, DMV and MB series valves and FRI series regulators.

**Gases**

Natural gas, propane, butane, air and other noncorrosive gases. Suitable for up to 0.1% by volume, dry H<sub>2</sub>S.

**Switch action**

GAO: high/low limit, NC breaks on rise, automatic reset  
GMH: high limit, NC breaks on rise, manual reset  
GML: low limit, NO breaks on fall, manual reset

**Switch Type and Contact Rating**

SPDT; 10 A res., 8 FLA, 48 LRA @120 Vac

**Vent Limiter**

Incorporates a vent limiter as per UL 353 and limits the escape of gas less than 1.0 CFH of natural gas at 7 PSI if internal switch diaphragm ruptures.

**Electrical Connection**

1/2" NPT conduit connection via screw terminals

**Enclosure Rating**

NEMA Type 4

**Maximum Operating Pressure**

7 PSI (500 mbar)

**Ambient / Fluid Temperature**

Versions -2, -3, -5, & -6; -40°F to +140°F; (-40°C to +60°C)  
Version -8; -20°F to +140°F; (-30°C to +60°C)

**Materials in contact with Gas**

Housing: aluminum & steel; Diaphragm: NBR-based rubber

**Approvals**

UL Listed: File #. MH 16628  
CSA Certified: File # 201527  
FM Approved: Report J.I. 1Y9A9.AF  
Commonwealth of Massachusetts Approved Product  
Approval code G3-0106-191



**ATTENTION**

- Read these instructions carefully.
- Failure to follow them and/or improper installation may cause explosion, property damage and injuries.
- Installation must be done with the supervision of a licensed burner technician.
- Check the ratings in the specifications to make sure that they are suitable for your application.
- Never perform work if gas pressure or power is applied, or in the presence of an open flame.
- Ensure that the switch is not subjected to vibration during operation.
- Once installed, perform a complete checkout including leak testing.
- Label all wires prior to disconnection when servicing. Wiring errors can cause improper and dangerous operation
- Verify proper operation after servicing.
- The system must be installed, used, and maintained to meet all applicable national and local code requirements such as but not limited to NFPA 85, NFPA 86, UL 795, CSD-1, ANSI Z83.4, ANSI Z83.18, ANSI Z21.13, and CSA B149.3.

## MOUNTING

### Recommended Mounting Procedure

- Remove the clear cover of the switch in order to remove the thread forming socket head screws.
- Verify that the O-ring and the groove, in which the O-ring is placed, are clean and free of notches or burrs.
- Place the O-ring into the groove on the back of the pressure switch. This is located on the flate side of the aluminum housing.
- Using a 3 mm hex wrench, remove the G 1/8 plug from the port on which the switch is to be mounted. This will be either a flange, the side of the FRI regulator, or a G 1/8 port of Dungs safety shutoff valve.
- Mount the switch onto the port using the thread-forming socket head screws.
- The O-ring can slide during the mounting process, so it is recommended that as the switch is pressed onto the port, visually verify that the O-ring remains in the groove.
- Tighten the screws but do not exceed 22 lb-in.
- Perform a leak test to verify that no leakage occurs around the O-ring.

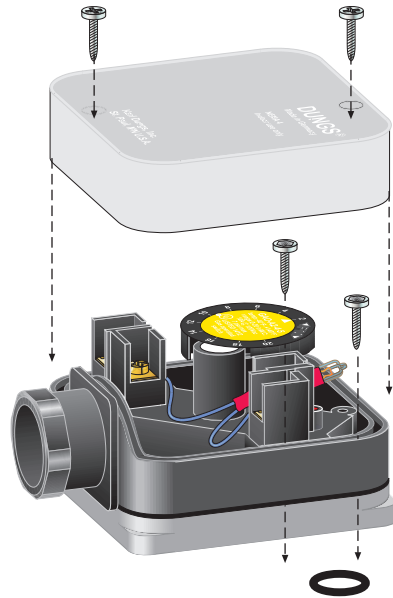

## WIRING

- Remove the clear cover from the switch.
- Use 14 or 16 AWG wire rated for at least 75°C
- Route the wires through the conduit connector
- Connect the wiring to the appropriate screw terminals.



**CAUTION:** All wiring must comply with local electrical codes, ordinances and regulations.



**CAUTION:** Do not exceed the switch ratings given in the specifications and on the switch.

**GAO (Operating state shown as a high limit). As pressure rises** above set point, 1 NC opens, 2 NO closes, Neon light ON (fault). **As pressure falls** below set point, switch resets: 1 NC closes and 2 NO opens.

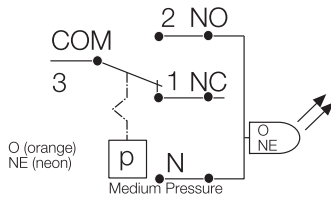

**GMH (Operating state shown) As pressure rises** above set-point, 2 NO closes, 1 NC opens, and Neon light ON (fault), switch trips and locks out.

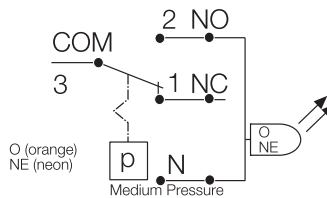

**GML (Operating state shown) As pressure falls** above set-point, 2 NO opens, 1 NC closes, Neon light ON (fault), switch trips and locks out.

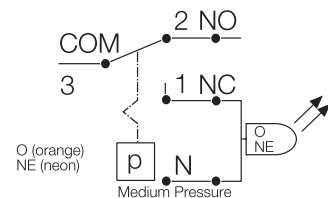

### Wiring terminal illustration

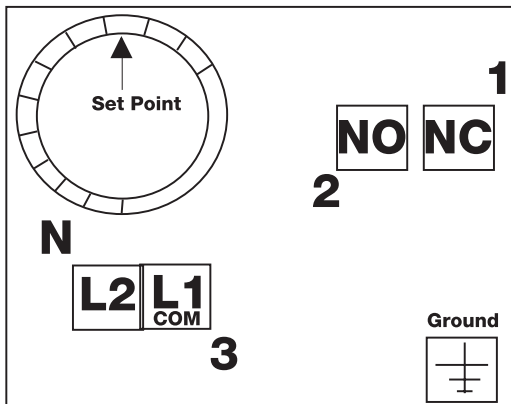

## OPERATION AND ADJUSTMENT

### **Annually check the switch for proper operation**

#### **Set Point Calibration**

The set point dial of the GAO and GMH is factory calibrated with increasing pressure (GML: decreasing pressure). Due to hysteresis, the GAO switch will actuate at a slightly lower point as the pressure decreases.

#### **Adjusting the Set Point**

- Remove the clear cover from the switch.
- Turn the dial until the desired trip pressure is opposite the white arrow (mark) on the yellow dial face.
- After adjusting the set point for normal operation check to see that the gas pressure switch operates as intended.
- Use an accurate pressure gauge connected upstream from the switch to measure the actual pressure.
- Replace the clear cover.

#### **Automatic Reset**

The NC contact of the GAO breaks when pressure rises above the set point. It makes automatically when pressure returns to the normal operating level.

#### **Manual Reset**

The NC contact of the GMH breaks when pressure rises above the set point. The NO contact of the GML breaks when pressure falls below the set point. Neither of the switches will return to their former position automatically. To reset, wait until the pressure returns to the normal operating level. Then press and release the clear cover over the red reset button in the center of the yellow dial face; it is not necessary to remove the cover. The neon light indicates a fault condition for the GML and GMH series and for the GAO series when used as a high gas limit. The lead for the light wired to terminal #2 on the GAO series should be wired to terminal #1 when used as a low gas limit.

## MAINTENANCE AND TESTING

### Annually check the switch for proper operation

#### Low Gas Pressure Switch:

- First, connect a meter capable of reading +/- 0 ohms to the NO and COM contacts, and verify that the NO and COM contacts are made. Measure the resistance, and if the resistance is more than 1 ohm, remove switch from service. is more than 1 ohm. (See terminal illustration below for guidance).
- Then, verify that the low gas pressure switch will change state when a low gas condition is sensed by connecting a meter capable or reading +/- 0 ohms to the NC and COM contacts and then by causing the switch to go into a fault condition. Once the fault occurs, Measure the resistance, and if the resistance is more than 1 ohm, remove switch from service. is more than 1 ohm.
- To cause the fault, perform one of the two procedures:
  1. Turn the pressure switch setpoint counterclockwise until the switch trips.
  2. Depressurize the volume of gas the low gas pressure switch is sensing. For FRI/6 regulators, this can be done by opening the side tap on the opposite side of the FRI/6 regulator. For DMV and MBC safety shutoff valves, this can be done opening the port 1 pressure tap. For SV valves, open port 1 of the upstream valve.
- Allow the burner to go through a startup sequence, and then verify that the burner faults and is not allowed to light off.
- Close all test taps (ports) and open upstream ball valve.
- When finished, close all pressure test points used, and then open the upstream ball valve **SLOWLY** to allow gas pressure to gradually bleed into the system.

**CAUTION: Opening the upstream ball valve too fast can permanently damage the regulator.**

 **Do not simulate fault conditions while the burner is firing.**

#### High Gas Pressure Switch:

- First, connect a meter capable of reading +/- 0 ohms to the NC and COM contacts, and verify that the NC and COM contacts are made. Measure the resistance, and if the resistance is more than 1 ohm, remove switch from service. is more than 1 ohm.
- Then, verify that the high gas pressure switch will change state when a high gas condition is sensed by connecting a meter capable or reading +/- 0 ohms to the NO and COM contacts and then by causing the switch to go into a fault condition.
- To cause the fault, perform one of the two procedures:
  1. Turn the pressure switch setpoint clockwise until the switch trips.
  2. Pressurize the volume of gas the high gas pressure switch is sensing. This can be done by closing the downstream ball valve, opening port 3 tap on a DMV and MBC safety shutoff valves, or port 2 or 3 of the downstream SV valve, and then using a pump to pressurize the test chamber.
- Measure the resistance across the NO and COM contacts. If the resistance is more than 1 ohm, remove switch from service.
- Allow the burner to go through a startup sequence, and then verify that the burner faults and is not allowed to light off.
- When finished, close all test taps (ports) and open the downstream ball valve.

**NOTE: A resistance of more than 1 ohm indicates that the switch contacts are starting to either corrode or carbonize.**

**Terminal Illustration**

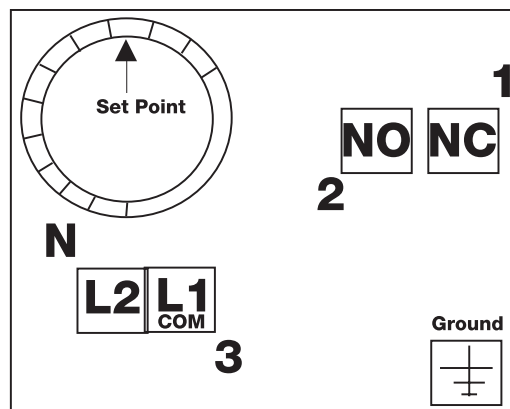

# MOUNTING TO SAFTY VALVES

## Location

Model series GAO-A2-4, GMH-A2-4, and GML-A2-4 can be mounted directly to various ports on a DUNGS valve. The pressure switch should be mounted in locations meeting the requirements of the applicable code. Order mounting kit 214-975 for DMV port 3 mount and MBC port 3 mounting, and kit 225-047 for mounting switch vertically on a valve flange.

## A2 mounting options

### DMV 701-703 Dual modular valve

Pressure tap	Mounting possible?
1	yes
2	yes
3	yes, with #214-975
4	yes, horizontal yes, vertical with #225-047
5	yes, horizontal yes, vertical with #225-047

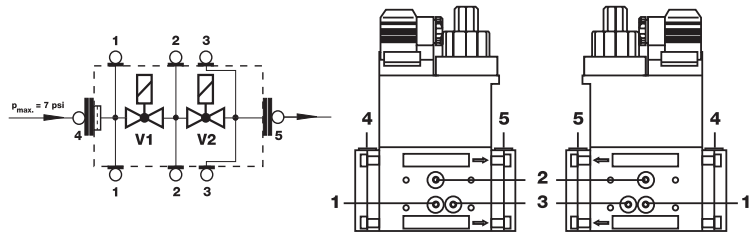

## A2 mounting options

### SV 1005 and SV 1007 series safety valve

Pressure tap	Mounting possible?
1	no
2	yes
3	no
4	no

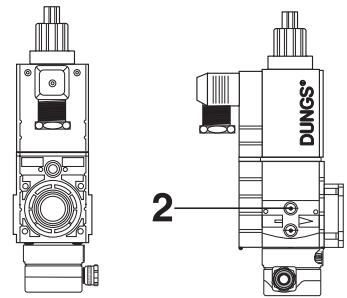
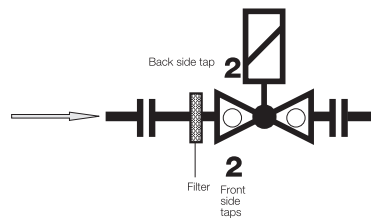

## A2 mounting options

### SV 1010, SV 1012, SV 1015, and SV 1020 series safety valve

Pressure tap	Mounting possible?
1	yes
2	yes
3	yes
4	no
5	yes

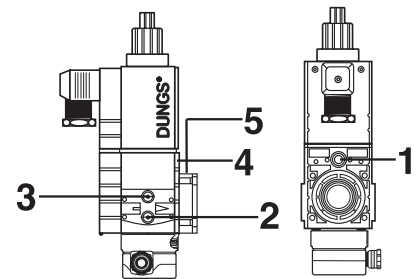
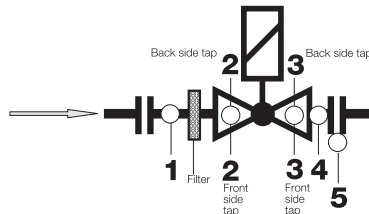

## A2 mounting options

### MBC series multifunctional control

Pressure tap	Mounting possible?
1	yes
2	yes
3	yes, with #214-975
4	yes, horizontal yes, vertical with #225-047
5	yes, horizontal yes, vertical with #225-047

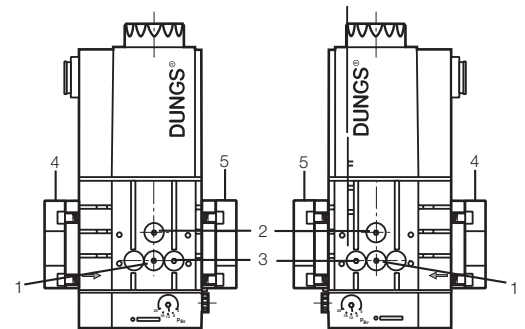
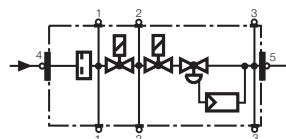

## MOUNTING TO SAFTY VALVES or FRI REGULATOR

### A2 mounting options DMV 525,5040-5125/11 dual modular valve

Pressure tap	Mounting possible?
1	yes
2	yes
3	yes
4	yes
5	no
6	no

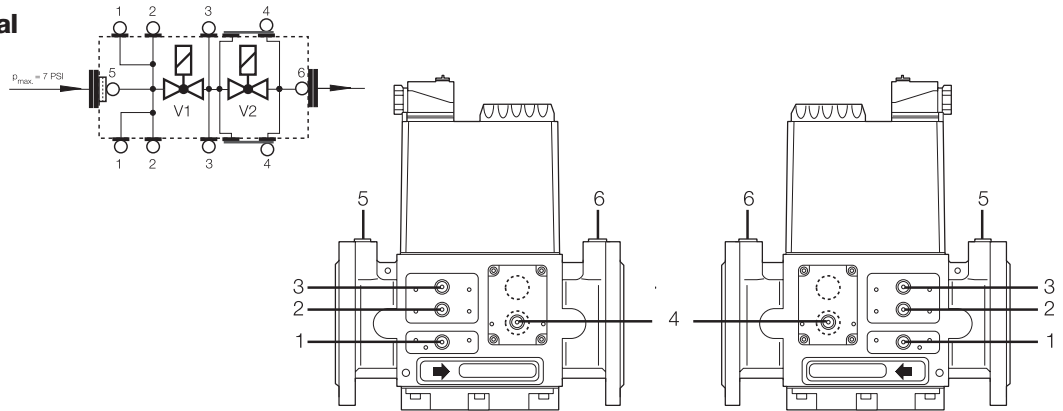

### A2 mounting options FRI gas pressure regulator

Pressure tap	Mounting possible?
1	yes
2	yes
3	yes

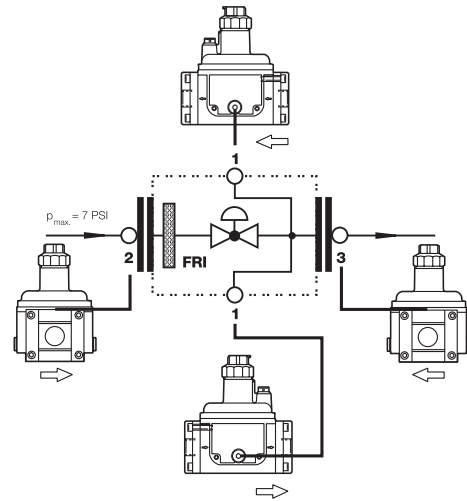

## REPLACEMENT PARTS

Replacement cover (screws not included)	228-732 (for GAO switches) and 233-113 (for GMH and GML switches)	
Screw for replacement cover	237-675	
PG11 - 1/2" NPT conduit adapter	220-566	
120VAC neon light	244-156 for orange	248-240 for green
24VAC/VDC light (orange)	244-157	
DIN connector (female plug)	210-318	
Male plug for DIN connector	219-659 (for GAO switches) and 227-644 (for GMH and GML switches)	
Mounting screw kit	226-188 (includes o-ring and two M4 thread forming screws)	
M20 - 1/2" NPT Adapter	240-671	
Port 3 adapter	214-975 (for MBC 1000-4000 series and DMV 701-703 series)	
Adapter with 1/4" NPT threaded connection and pressure tap for vertically mounting pressure switch on a SV, DMV, or MBC flange.	225-047	